

Chengdu RF Miso Co., Ltd.

📍 No.259, ZhengGang Road, South District Modern Industrial Port,
Pidu District, ChengDu City, Sichuan Province, China

🌐 www.rf-miso.com

✉ info@rf-miso.com

☎ 0086-028-82695327

0086-17340103033

ANTENNAS AND
PASSIVE COMPONENTS MANUFACTURER

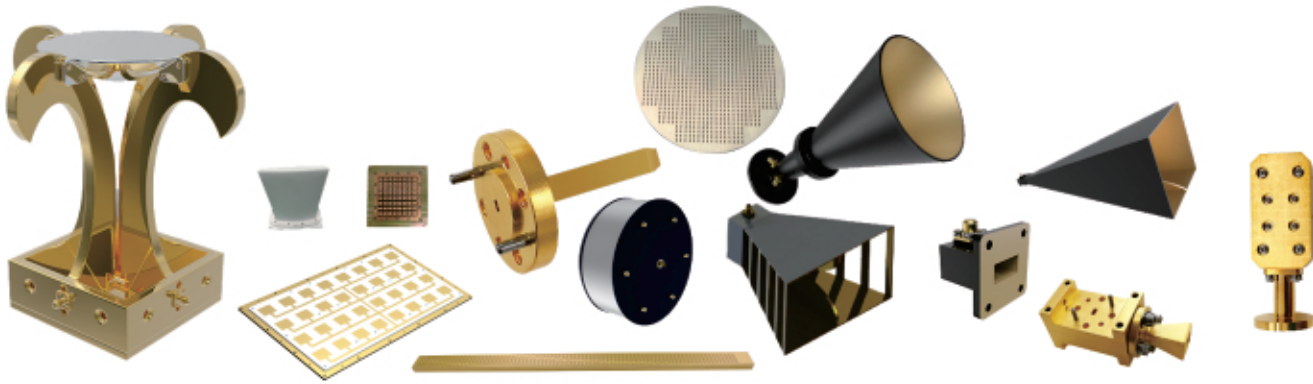

ABOUT US

RF MISO is a high-tech enterprise specializing in the R&D and production of antennas and communication devices. Since our establishment, we have been committed to the R&D, innovation, design, production and sales of antennas and communication devices. Our team is composed of doctors, masters, senior engineers and skilled front-line workers, with solid professional theoretical foundation and rich practical experience. "Be focus, Be professor" is our slogan. In our team, the close cooperation of innovative research and development and precision production enables us to achieve the three goals of the enterprise: to achieve the best performance and excellent quality of various types of standard antennas, to serve well the needs of customers for various customized antennas, such as waveguide slot antennas, etc, in the case of the customer's design, meet the customer's demand for production and manufacturing. Our products are widely used in various commercial applications, experiments, test systems and many other applications.

CONTENTS

1 Standard Gain Horn Antenna-----	02-04
2 Broadband Horn Antenna-----	06-07
3 Broadband Dual Polarized Horn Antenna-----	08
4 Conical Dual Polarized Horn Antenna-----	09
5 OMT Dual Polarized Antenna-----	10
6 Circular Polarized Horn Antenna-----	11
7 Dual Circular Polarized Horn Antenna-----	12
8 Corrugated Horn Antenna-----	13-14
9 Planar Antenna-----	15
10 Planar Spiral Antenna-----	16
11 Log Spiral Antenna-----	17
12 Log Periodic Antenna-----	18
13 Microstrip Array Antenna -----	19
14 Triangular Reflector-----	20
15 Waveguide Probe-----	21
16 Right Angle Waveguide to Coaxial Adapter-----	22
17 Vacuum Welding Products-----	23-24

Naming Rules

RM: RF Miso
SGHA: Standard Gain Horn Antenna
RM-SGHA430-10
10: Gain 10dBi
430: Waveguide 430

RM: RFMiso
DPHA: Dual Polarization Horn Antenna
RM-DPHA918-15
15: Gain 15dBi
918: 9GHz-18GHz

Examples:

RM-SGHA430-10 is Standard Gain Horn Antenna, Waveguid 430, Gain 10dBi.

RM-BDHA18-15 is Broadband Horn Antenna, 1GHz-8GHz, Gain 15dBi.

RM-DPHA618-15 is Dual Polarization Horn Antenna, 6GHz-18GHz, Gain 15dBi.

RM-CHA3040-10 is Corrugated Horn Antenna, 30GHz-40GHz, Gain 10dBi.

Customized Service	Process	Requirment collection, desgin, sample, test
	Cost	According to antenna design, production process and materials
	Shipment	Estimated by antenna
Payment		TT 100%(Telegraphic Transfer)
Product Shipment	Stock and Leadtime	On stock product supply in 5 days
	Shipment	UPS, Fedex, DHL
	Package	Wooden box, Carton
Available Accessories (Not Free)	1	Installation fixture
	2	Tripod
	3	Antenna radome
	4	Packing box

1 Standard Gain Horn Antenna

Standard gain horn antennas provided by RF Miso adopts linear polarization, which provides an efficient and economical method for measurement. The standard gain horn antenna series antennas cover the frequency from 1.7GHz to 500GHz in an overlapping way. These horn antennas can be widely used in EMI detection, orientation, reconnaissance, antenna gain and pattern measurement and other applications. This series of horn antennas has the characteristics of high gain, low VSWR, and light appearance.



Frequency:	1.7GHz-500GHz
VSWR:	<1.5 1.25(Type.)
Gain:	10dBi, 15dBi, 20dBi
Interface:	Waveguide, Coaxial

For Example

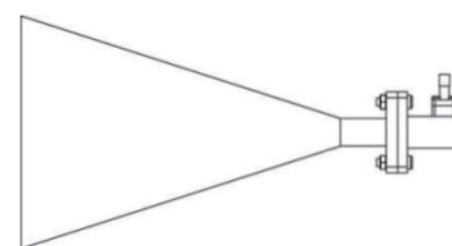

Volt Standing Wave Ratio

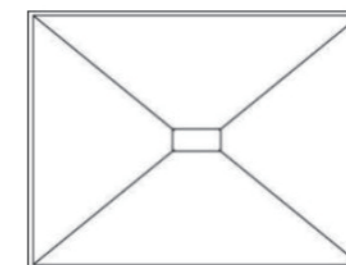
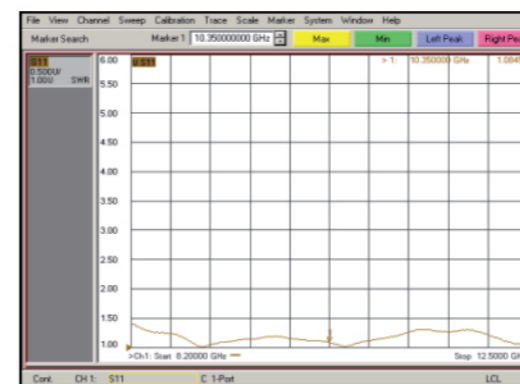

Gain

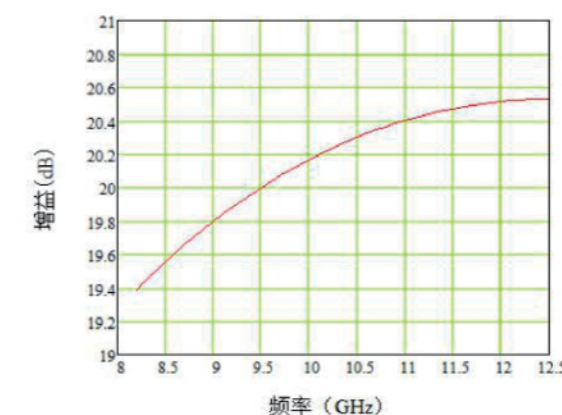

Model	Frequency (GHz)	Gain (dBi)	Wave guide	Type	Interface	Dimension(mm)			Material	Datash eet
						W	H	L		
RM-SGHA430-10	1.7-2.6	10	WR430	F	FDP22	170.1	137	200	Al	Detail
RM-SGHA430-10		10		C	N-K	170.1	137	351	Al	Detail
RM-SGHA430-15		15		F	FDP22	300.1	217	372	Al	Detail
RM-SGHA430-15		15		C	N-K	300.1	217	523	Al	Detail
RM-SGHA430-20		20		F	FDP22	538.2	400	1105	Al	Detail
RM-SGHA430-20		20		C	N-K	538.2	400	1256	Al	Detail
RM-SGHA284-10	2.6-3.95	10	WR284	F	FDP32	114.3	92	129.9	Al	Detail
RM-SGHA284-10		10		C	N-K	114.3	92	232.9	Al	Detail
RM-SGHA284-15		15		F	FDP32	199.7	145	245.3	Al	Detail
RM-SGHA284-15		15		C	N-K	199.7	145	348.3	Al	Detail
RM-SGHA284-20		20		F	FDP32	356.8	266	730	Al	Detail
RM-SGHA284-20		20		C	N-K	356.8	266	833	Al	Detail
RM-SGHA229-10	3.3-4.9	10	WR229	F	FDP40	98.4	77	105	Al	Detail
RM-SGHA229-10		10		C	N-K	98.4	84	189.5	Al	Detail
RM-SGHA229-15		15		F	FDP40	161.8	118	197.8	Al	Detail
RM-SGHA229-15		15		C	N-K	161.8	118	282.3	Al	Detail
RM-SGHA229-20		20		F	FDP40	290.6	217	589	Al	Detail
RM-SGHA229-20		20		C	N-K	290.6	217	673.5	Al	Detail
RM-SGHA187-10	3.95-5.85	10	WR187	F	FDP48	88.9	64	86	Al	Detail
RM-SGHA187-10		10		C	N-K	88.9	74	158.1	Al	Detail
RM-SGHA187-15		15		F	FDP48	133	97	161.7	Al	Detail
RM-SGHA187-15		15		C	N-K	133	97	233.7	Al	Detail
RM-SGHA187-20		20		F	FDP48	236.6	177	480.2	Al	Detail
RM-SGHA187-20		20		C	N-K	236.6	177	552.3	Al	Detail
RM-SGHA159-10	4.9-7.05	10	WR159	F	FDP58	81	62	80	Al	Detail
RM-SGHA159-10		10		C	N-K	81	73	137.3	Al	Detail
RM-SGHA159-15		15		F	FDP58	113.6	83	137.3	Al	Detail
RM-SGHA159-15		15		C	N-K	113.6	84	194.6	Al	Detail
RM-SGHA159-20		20		F	FDP58	201.6	151	407.9	Al	Detail
RM-SGHA159-20		20		C	N-K	201.6	151	465.2	Al	Detail
RM-SGHA137-10	5.85-8.2	10	WR137	F	FDP70	68.3	49	80	Al	Detail
RM-SGHA137-10		10		C	SMA-F	68.3	49	133.7	Al	Detail
RM-SGHA137-15		15		F	FDP70	98.3	72	118.1	Al	Detail
RM-SGHA137-15		15		C	SMA-F	98.3	72	171.8	Al	Detail
RM-SGHA137-20		20		F	FDP70	174	130	351	Al	Detail
RM-SGHA137-20		20		C	SMA-F	174	130	404.6	Al	Detail
RM-SGHA112-10	6.57-9.99	10	WR112	F	FBP84	48.4	48	60	Al	Detail
RM-SGHA112-10		10		C	SMA-F	48.4	48	103.1	Al	Detail
RM-SGHA112-15		15		F	FBP84	83.5	62	96.9	Al	Detail
RM-SGHA112-15		15		C	SMA-F	83.5	62	140	Al	Detail
RM-SGHA112-20		20		F	FBP84	143.4	107	290	Al	Detail
RM-SGHA112-20		20		C	SMA-F	143.4	108	333.1	Al	Detail

Model	Frequency (GHz)	Gain (dBi)	Wave guide	Type	Interface	Dimension(mm)			Material	Datash eet
						W	H	L		
RM-SGHA90-10	8.2-12.5	10	WR90	F	FBP100	41.4	41	47	Al	Detail
RM-SGHA90-10		10		C	SMA-F	41.4	41	84.3	Al	Detail
RM-SGHA90-15		15		F	FBP100	66.2	49	85	Al	Detail
RM-SGHA90-15		15		C	SMA-F	66.2	49	122.3	Al	Detail
RM-SGHA90-20		20		F	FBP100	115.9	87	238	Al	Detail
RM-SGHA90-20		20		C	SMA-F	115.9	87	275.3	Al	Detail
RM-SGHA75-10	9.84-15	10	WR75	F	FBP120	38	38	44	Al	Detail
RM-SGHA75-10		10		C	SMA-F	38	39	75.8	Al	Detail
RM-SGHA75-15		15		F	FBP120	55.9	42	64.8	Al	Detail
RM-SGHA75-15		15		C	SMA-F	55.9	42	96.5	Al	Detail
RM-SGHA75-20		20		F	FBP120	99.3	75	195	Al	Detail
RM-SGHA75-20		20		C	SMA-F	99.3	75	226.8	Al	Detail
RM-SGHA62-10	11.9-18	10	WR62	F	FBP140	33.3	33	32.1	Al	Detail
RM-SGHA62-10		10		C	SMA-F	33.3	36	61	Al	Detail
RM-SGHA62-15		15		F	FBP140	47.1	35	57.4	Al	Detail
RM-SGHA62-15		15		C	SMA-F	47.1	37	86.3	Al	Detail
RM-SGHA62-20		20		F	FBP140	81.3	61	163.2	Al	Detail
RM-SGHA62-20		20		C	SMA-F	81.3	61	192.1	Al	Detail
RM-SGHA51-10	14.5-22	10	WR51	F	FBP180	30.2	30	35	Al	Detail
RM-SGHA51-10		10		C	SMA-F	30.2	34	62.5	Al	Detail
RM-SGHA51-15		15		F	FBP180	38.3	30	51.8	Al	Detail
RM-SGHA51-15		15		C	SMA-F	38.3	34	79.3	Al	Detail
RM-SGHA51-20		20		F	FBP180	67.4	51	138.6	Al	Detail
RM-SGHA51-20		20		C	SMA-F	67.4	51	166	Al	Detail
RM-SGHA42-10	17.6-26.7	10	WR42	F	FBP220	22.4	22	26	Al	Detail
RM-SGHA42-10		10		C	SMA-F	22.4	30	46.5	Al	Detail
RM-SGHA42-15		15		F	FBP220	32	24	45	Al	Detail
RM-SGHA42-15		15		C	SMA-F	32	30	65.5	Al	Detail
RM-SGHA42-20		20		F	FBP220	56.2	43	110	Al	Detail
RM-SGHA42-20		20		C	SMA-F	56.2	43	130.5	Al	Detail
RM-SGHA34-10	21.7-33	10	WR34	F	FBP260	21.1	21	26	Al	Detail
RM-SGHA34-10		10		C	SMA-F	21.1	28	48.3	Al	Detail
RM-SGHA34-15		15		F	FBP260	26.5	21	40	Al	Detail
RM-SGHA34-15		15		C	SMA-F	26.5	28	62.3	Al	Detail
RM-SGHA34-20		20		F	FBP260	46.3	35	93	Al	Detail
RM-SGHA34-20		20		C	SMA-F	46.3	35	115.3	Al	Detail
RM-SGHA28-10	26.5-40	10	WR28	F	FBP320	19.1	19	21.4	Al	Detail
RM-SGHA28-10		10		C	2.92-F	19.1	27	41.5	Al	Detail
RM-SGHA28-15		15		F	FBP320	21.4	19	34	Al	Detail
RM-SGHA28-15		15		C	2.92-F	21.4	27	54	Al	Detail
RM-SGHA28-20		20		F	FBP320	19.1	19	21.4	Al	Detail
RM-SGHA28-20		20		C	2.92-F	19.1	27	41.5	Al	Detail

Model	Frequency (GHz)	Gain (dBi)	Wave guide	Type	Interface	Dimension(mm)			Material	Datash eet
						W	H	L		
RM-SGHA19-10	40-60	10	WR19	F	FUGP500	8	6	15	Cu	Detail
RM-SGHA19-10		10		C	2.4mm-K	8	6	20	Cu	Detail
RM-SGHA19-15		15		F	FUGP500	17	12	22	Cu	Detail
RM-SGHA19-15		15		C	2.4mm-K	17	12	27	Cu	Detail
RM-SGHA19-20		20		F	FUGP500	29	22	50	Cu	Detail
RM-SGHA19-20		20		C	2.4mm-K	29	22	55	Cu	Detail
RM-SGHA15-10	50-75	10	WR15	F	FUGP620	6	5	14	Cu	Detail
RM-SGHA15-10		10		C	1.85MM-K	6	5	18	Cu	Detail
RM-SGHA15-15		15		F	FUGP620	13	9	19	Cu	Detail
RM-SGHA15-15		15		C	1.85MM-K	13	9	23	Cu	Detail
RM-SGHA15-20		20		F	FUGP620	23	18	42	Cu	Detail
RM-SGHA15-20		20		C	1.85MM-K	23	18	46	Cu	Detail
RM-SGHA12-10	60-90	10	WR12	F	FUGP740	5	4	13	Cu	Detail
RM-SGHA12-10		10		C	1.0mm-K	5	4	17	Cu	Detail
RM-SGHA12-15		15		F	FUGP740	11	8	18	Cu	Detail
RM-SGHA12-15		15		C	1.0mm-K	11	8	21	Cu	Detail
RM-SGHA12-20		20		F	FUGP740	19	15	37	Cu	Detail
RM-SGHA12-20		20		C	1.0mm-K	19	15	40	Cu	Detail
RM-SGHA10-10	75-110	10	WR10	F	FUGP900	4	3	12	Cu	Detail
RM-SGHA10-10		10		C	1.0mm-K	4	3	15	Cu	Detail
RM-SGHA10-15		15		F	FUGP900	9	6	16	Cu	Detail
RM-SGHA10-15		15		C	1.0mm-K	9	6	19	Cu	Detail
RM-SGHA10-20		20		F	FUGP900	15	12	31	Cu	Detail
RM-SGHA10-20		20		C	1.0mm-K	15	12	34	Cu	Detail
RM-SGHA8-10	90-140	10	WR8	F	UG387	3	2	12	Cu	Detail
RM-SGHA8-15		15		F	UG387	7	5	15	Cu	Detail
RM-SGHA8-20		20		F	UG387	12	10	28	Cu	Detail
RM-SGHA6-10	110-170	10	WR6	F	UG-387/U-M	3	2	12	Cu	Detail
RM-SGHA6-15		15		F	UG-387/U-M	6	4	14	Cu	Detail
RM-SGHA6-20		20		F	UG-387/U-M	10	8	24	Cu	Detail
RM-SGHA5-10	140-220	10	WR5	F	UG387	2	1	11	Cu	Detail
RM-SGHA5-15		15		F	UG387	4	3	13	Cu	Detail
RM-SGHA5-20		20		F	UG387	8	6	21	Cu	Detail
RM-SGHA4-10	170-260	10	WR4	F	APF4	1	1	11	Cu	Detail
RM-SGHA4-15		15		F	APF4	4	2	12	Cu	Detail
RM-SGHA4-20		20		F	APF4	6	5	19	Cu	Detail
RM-SGHA3-10	220-325	10	WR3	F	APF3	1	1	11	Cu	Detail
RM-SGHA3-15		15		F	APF3	3	2	12	Cu	Detail
RM-SGHA3-20		20		F	APF3	5	4	17	Cu	Detail
RM-SGHA2.2-10	325-500	10	WR2.2	F	APF2.2	1	0.7	10	Cu	Detail
RM-SGHA2.2-15		15		F	APF2.2	2	1	11	Cu	Detail
RM-SGHA2.2-20		20		F	APF2.2	3	2	15	Cu	Detail

2 Broadband Horn Antenna

The wideband horn antennas provided by RF Miso adopts linear polarization, which provides an efficient and economical method for wideband measurement. The broadband horn series antennas can cover the frequency from 100MHz to 110GHz, these horn antennas can be widely used in EMI detection, orientation, reconnaissance, antenna gain and pattern measurement and other application fields. This series of horn antennas has the characteristics of high gain, high frequency doubling, low VSWR, and light appearance. We can customize various special specifications according to the needs of customers, especially broadband horn antennas with special requirements for gain. The test report is for reference only.



Frequency:	0.1-110GHz
VSWR:	≤2.5
Gain:	6-15dBi
Interface:	Connector

Volt Standing Wave Ratio

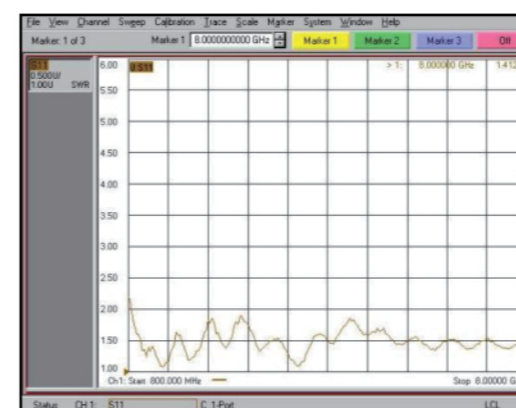

Gain

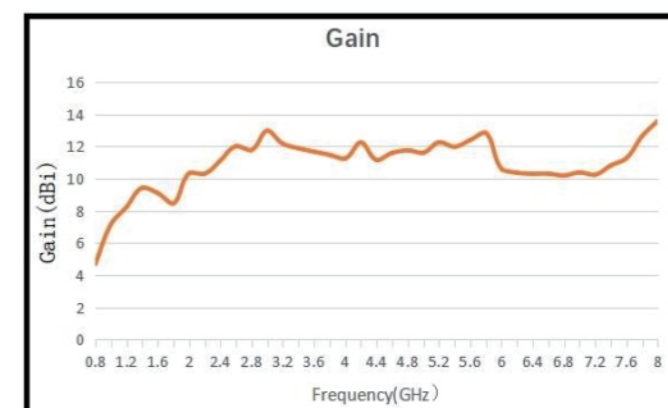

Model	Frequency (GHz)	Polarizaiton	Gain (dBi)	Connector	Dimension(mm)			Material	Datash eet
					W	H	L		
RM-BDHA011-7	0.1-1	Linear	6	N-K	2250	2164	1400	Al	Detail
RM-BDHA0225-12	0.2-2.5	Linear	10	N-K	950	700	900	Al	Detail
RM-BDHA0352-14	0.35-2	Linear	14	N-K	541	473	915	Al	Detail
RM-BDHA0406-9	0.4-0.6	Linear	9	N-K	699	413	1040	Al	Detail
RM-BDHA0507-9	0.5-0.7	Linear	9	N-K	583	345	882	Al	Detail
RM-BDHA046-10	0.4-6	Linear	10	N-K	320	430	490	Al	Detail

Model	Frequency (GHz)	Polarization	Gain (dBi)	Connector	Dimension(mm)			Material	Data sheet
					W	H	L		
RM-BDHA056-11	0.5-6	Linear	11	SMA-F	384	292	369	Al	Detail
RM-BDHA066-11	0.6-6	Linear	11	N-50KFD	442	290	344	Al	Detail
RM-BDHA071-9	0.7-1	Linear	9	N-K	381	226	559	Al	Detail
RM-BDHA088-10N	0.8-8	Linear	10	N-K	288	162	230	Al	Detail
RM-BDHA12-12	1-2	Linear	12	N-K	256	214	550	Al	Detail
RM-BDHA14-10	1-4	Linear	10	N-K	251	172	256	Al	Detail
RM-BDHA112-10	1-12	Linear	10	SMA-K	244	160	204	Al	Detail
RM-BDHA118-10	1-18	Linear	10	SMA-F	186	109	175	Al	Detail
RM-BDHA26-13	2-6	Linear	13	SMA-F	123	108	199	Al	Detail
RM-BDHA26-15	2-6	Linear	15	N-K	245	195	407	Al	Detail
RM-BDHA28-12	2-8	Linear	12	SMA-K	104	78	127	Al	Detail
RM-BDHA218-10	2-18	Linear	10	SMA-F	106	89.9	142	Al	Detail
RM-BDHA220-12	2-20	Linear	12	SMA-K	104	78	127	Al	Detail
RM-BDHA48-22	4-8	Linear	22	SMA-F	338	268	603	Al	Detail
RM-BDHA48-20	4-8	Linear	20	SMA-F	290	240	585	Al	Detail
RM-BDHA440-13	4-40	Linear	13	2.4-F	60.4	47.7	58.3	Al	Detail
RM-BDHA618-10A	6-18	Linear	10	SMA-F	54	38	52.2	Al	Detail
RM-BDHA618-10B	6-18	Linear	10	N-F	58.1	52.8	116	Al	Detail
RM-BDHA618-12	6-18	Linear	12	SMA-F	43.7	43	69	Al	Detail
RM-BDHA618-15A	6-18	Linear	15	SMA-F	64.9	56.9	112	Al	Detail
RM-BDHA618-15B	6-18	Linear	15	2.92-F	76.1	64.1	181	Al	Detail
RM-BDHA667-13	6-67	Linear	13	1.85-F	43.6	40.1	35.8	Al	Detail
RM-BDHA818-10	8-18	Linear	10	SMA-F	55	43.1	99	Al	Detail
RM-BDHA818-20A	8-18	Linear	20	2.92-F	119	101	228	Al	Detail
RM-BDHA818-22	8-18	Linear	22	SMA-F	196	158	399	Al	Detail
RM-BDHA1840-13	18-40	Linear	13	2.92-F	30.6	27.9	38.2	Al	Detail
RM-BDHA1840-14	18-40	Linear	14	2.92-F	40	40	44	Al	Detail
RM-BDHA1840-15A	18-40	Linear	15	2.92-F	63.7	47.8	80	Al	Detail
RM-BDHA1840-15B	18-40	Linear	15	2.92-F	36.1	31.1	66.1	Al	Detail
RM-BDHA1850-15	18-50	Linear	15	2.4-F	36	31	71.2	Al	Detail
RM-BDHA1850-20	18-50	Linear	20	2.4-F	49.1	42.1	98.2	Al	Detail
RM-BDHA3337-25	33-37	Linear	25	2.92-F	77.8	62.7	221	Al	Detail
RM-BDHA10110-13	10-110	Linear	13	1.0mm-K	41	41	65	Al	Detail
RM-BDHA18110-14	18-110	Linear	14	1.0mm-K	41	41	65	Al	Detail

3 Broadband Dual Polarized Horn Antenna

The broadband dual polarized horn antennas are a pair of ridge structures added to the waveguide part of the pyramidal horn and the horn opening part to expand the working frequency bandwidth of the pyramidal horn. These antennas have a wide frequency bandwidth, small size and other characteristics, are widely used in EMC testing, direction finding, reconnaissance, antenna measurement and other applications. Broadband double-ridged horn antennas with various gains and wavebeam width requirements can be customized according to customer needs.



Frequency: 0.8-110GHz

VSWR: ≤2.5

Gain: 6-25dBi

Interface: Connector

Volt Standing Wave Ratio

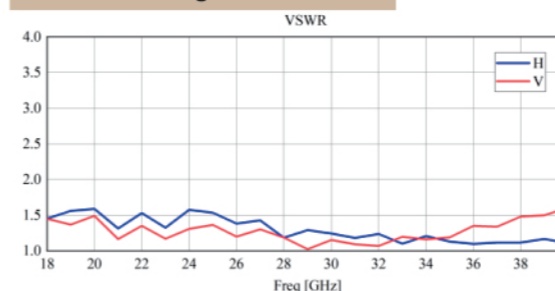

Gain

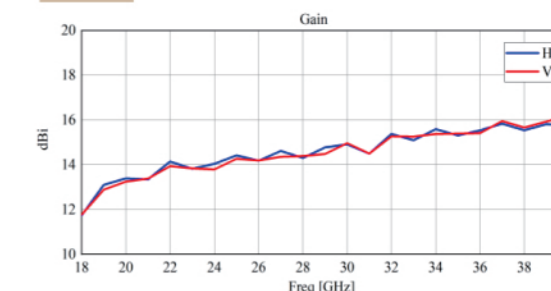

Model	Frequency (GHz)	Polarization	Gain (dBi)	Connector	Dimension(mm)			Material	Data sheet
					W	H	L		
RM-BDPHA082-6	0.8-2	Dual Linear	6	SMA-K	194	194	214	Al	Detail
RM-BDPHA083-7	0.8-3	Dual Linear	7	SMA-K	210	210	272	Al	Detail
RM-BDPHA0812-11	0.8-12	Dual Linear	11	SMA-K	329	329	444	Al	Detail
RM-BDPHA0818-12	0.8-18	Dual Linear	12	SMA-K	202	202	221	Al	Detail
RM-BDPHA218-15	2-18	Dual Linear	15	SMA-K	303	211	211	Al	Detail
RM-BDPHA618-12	6-18	Dual Linear	12	SMA-K	43	43	74	Al	Detail
RM-BDPHA1840-15A	18-40	Dual Linear	15	2.92-K	37	38	62.9	Al	Detail
RM-BDPHA1840-15E	18-40	Dual Linear	15	2.4mm-F	35.2	35	63.5	Al	Detail
RM-BDPHA1854-15	18-54	Dual Linear	15	2.4mm-F	61.3	61	67.2	Al	Detail
RM-BDPHA3238-14	32-38	Dual Linear	14	2.92-F	67.2	60	60	Al	Detail
RM-BDPHA4244-21	42-44	Dual Linear	21	SMA-K	30.9	33	95.8	Al	Detail
RM-BDPHA9395-22A	93-95	Dual Linear	22	WR10	19.1	21	69.3	Al	Detail

4 Conical Dual Polarized Horn Antenna

The conical dual polarized horn antennas adopt quad-ridged waveguide and dual-port feed to achieve broadband and dual-polarization respectively. A antenna not only has ultra-wideband characteristics, high isolation, but also has the advantages of small size, high gain and aperture efficiency.



Frequency: 0.8-110GHz

VSWR: ≤ 2.5

Gain: 6-25dBi

Interface: Connector

Volt Standing Wave Ratio

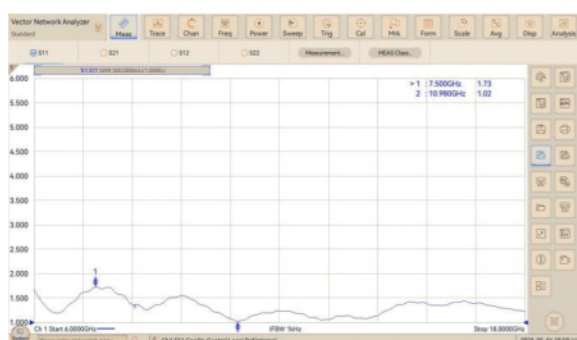

Gain

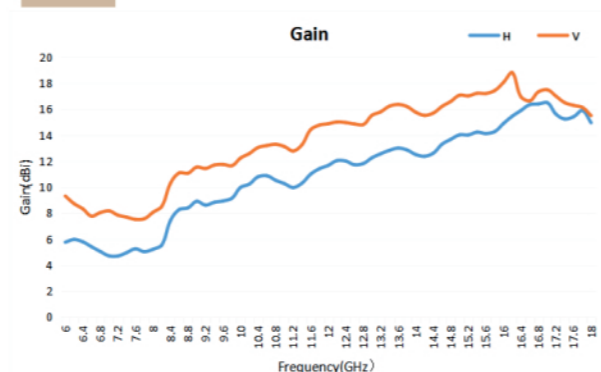

Model	Frequency (GHz)	Polarization	Gain (dBi)	Connector	Dimension(mm)			Material	Data sheet
					W	H	L		
RM-CDPAH082-8	0.8-2	Dual Linear	8	SMA-K	268	268	386	Al	Detail
RM-CDPHA0818-12	0.8-18	Dual Linear	12	SMA-K	198	198	295	Al	Detail
RM-CDPHA26-12	2-6	Dual Linear	12	SMA-K	309	196	196	Al	Detail
RM-CDPHA218-15	2-18	Dual Linear	15	SMA-K	145	145	273	Al	Detail
RM-CDPHA618-17	6-18	Dual Linear	17	SMA-K	132	132	237	Al	Detail
RM-CDPHA618-20	6-18	Dual Linear	20	2.92-K	125	125	236	Al	Detail
RM-CDPHA2334-20	23-34	Dual Linear	20	2.92-K	61.7	62	169	Al	Detail
RM-CDPHA3238-21	32-38	Dual Linear	21	2.92-K	43.1	43	110	Al	Detail
RM-CDPHA26540	26.5-40	Dual Linear	20	2.92-K	/	/	/	Al	Detail
RM-CDPHA3337-20	33-37	Dual Linear	20	2.92-K	55	55	146	Al	Detail
RM-CDPHA4244-18	42-44	Dual Linear	18	2.4mm-K	34.8	35	66.5	Cu	Detail
RM-CDPHA9395-19A	93-95	Dual Linear	19	WR-10	19.1	19	65	Cu	Detail

5 OMT Dual Polarized Antenna

The OMT dual-polarized horn antennas break through the limitations of the quad-ridged horn antenna and achieve high isolation. So his application is more and more extensive. By matching with various antennas, such as conical antennas, rectangular antennas, lens antennas, etc., various antennas can be obtained to suit any system application. The frequency range of RF MISO's OMT antenna is 10-110GHz, the material is copper, the surface is gold-plated, and the connection structure is strong.

For Example

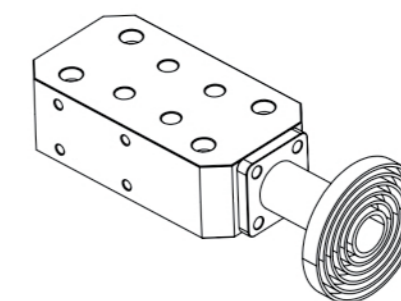

Volt Standing Wave Ratio

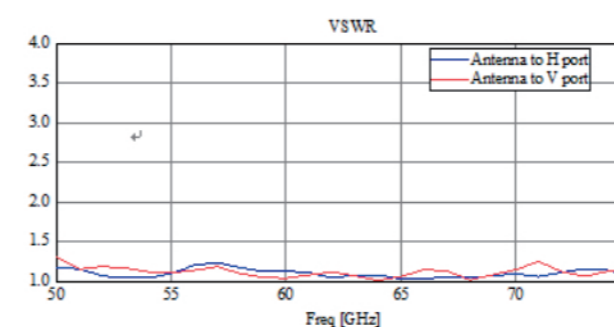

Gain

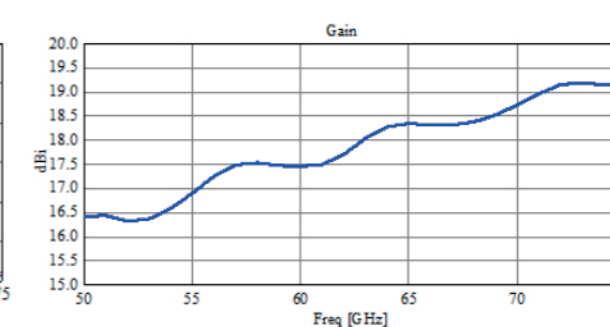

Model	Frequency (GHz)	Polarization	Gain (dBi)	Connector	Dimension(mm)			Material	Data sheet
					W	H	L		
RM-DPHA2442-10	24-42	Dual Linear	10	WR28	31.9	33	85.5	Brass	Detail
RM-DPHA3350-17	33-50	Dual Linear	17	WR22	40.9	41	73.5	Brass	Detail
RM-DPHA5075-18	50-75	Dual Linear	18	WR15	27.9	28	56	Brass	Detail
RM-DPHA6090-16	60-90	Dual Linear	16	WR12	27.9	28	51.7	Brass	Detail
RM-DPHA75110-18	75-110	Dual Linear	18	WR10	27.9	28	52.2	Brass	Detail
RM-DPHA75110-20	75-110	Dual Linear	20	WR10	27.9	28	61.2	Brass	Detail

6 Circular Polarized Horn Antenna

The circular polarized horn antennas are composed of a circular polarizer and a square horn antenna or a conical horn antenna. It is equalized in the azimuth plane and the elevation plane. The circular polarized horn antenna provided by our company can cover any frequency band from 1GHz to 110GHz, and the polarization mode can be left-handed circular polarization, right-handed circular polarization or dual circular polarization.

For Example

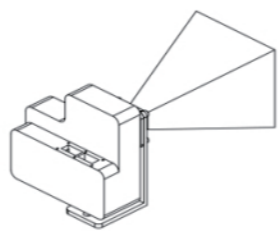
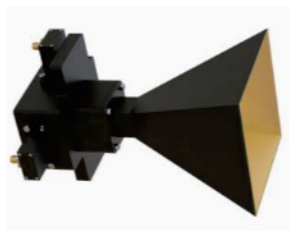

Volt Standing Wave Ratio

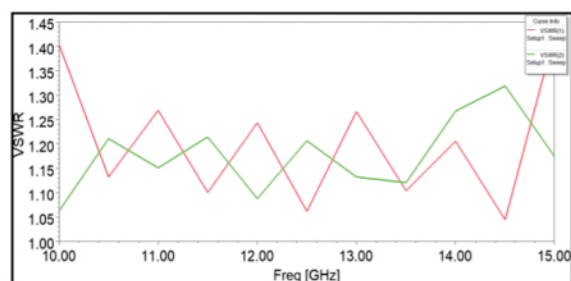

Gain

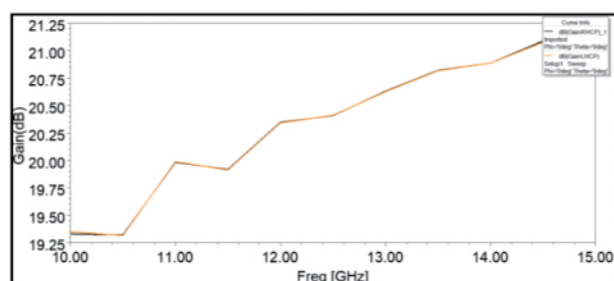

Model	Frequency (GHz)	Polarization	Gain (dBi)	VSWR	Interface	Dimension			Datasheet
						L	W	H	
RM-CPHA12-10	1-2	L-CP/R-CP	10	≤2	waveguide	/	/	/	Detail
RM-CPHA12-10	1-2	L-CP/R-CP	10	≤2	N-K	/	/	/	Detail
RM-CPHA24-10	2-4	L-CP/R-CP	10	≤2	waveguide	/	/	/	Detail
RM-CPHA24-10	2-4	L-CP/R-CP	10	≤2	N-K	/	/	/	Detail
RM-CPHA48-15	4-8	L-CP/R-CP	15	≤2	waveguide	417	81	67	Detail
RM-CPHA48-15	4-8	L-CP/R-CP	15	≤2	N-K/SMA-K	/	/	/	Detail
RM-CPHA82124-15	8.2-12.4	L-CP/R-CP	15	≤2	waveguide	/	/	/	Detail
RM-CPHA82124-15	8.2-12.4	L-CP/R-CP	15	≤2	SMA-K	/	/	/	Detail
RM-CPHA818-15	8-18	L-CP/R-CP	15	≤2	waveguide	/	/	/	Detail
RM-CPHA818-15	8-18	L-CP/R-CP	15	≤2	SMA-K	/	/	/	Detail
RM-CPHA1114-15	11-14	L-CP/R-CP	15	≤2	waveguide	/	/	/	Detail
RM-CPHA1114-15	11-14	L-CP/R-CP	15	≤2	N-K/SMA-K	/	/	/	Detail
RM-CPHA1840-15	18-40	L-CP/R-CP	15	≤2	waveguide	/	/	/	Detail
RM-CPHA1840-15	18-40	L-CP/R-CP	15	≤2	2.92mm-K	/	/	/	Detail
RM-CPHA235435-15	23.5-43.5	L-CP/R-CP	15	≤2	waveguide	/	/	/	Detail
RM-CPHA235435-15	23.5-43.5	L-CP/R-CP	15	≤2	2.4mm-K/2.92mm-K	/	/	/	Detail

RM-CPHA3643-15	36-43	L-CP/R-CP	15	≤2	waveguide	/	/	/	Detail
RM-CPHA3643-15	36-43	L-CP/R-CP	15	≤2	2.4mm-K	/	/	/	Detail
RM-CPHA6486-15	64-86	L-CP/R-CP	15	≤2	waveguide	/	/	/	Detail
RM-CPHA6486-15	64-86	L-CP/R-CP	15	≤2	1.0mm-K	/	/	/	Detail
RM-CPHA7599-15	75-99	L-CP/R-CP	15	≤2	waveguide	/	/	/	Detail
RM-CPHA7599-15	75-99	L-CP/R-CP	15	≤2	1.0mm-K	/	/	/	Detail

7 Dual Circular Polarized Horn Antenna

RF Miso's dual circular polarized horn antennas are implemented in two ways. One is Ortho-mode Transducers (OMT) with a waveguide polarizer, which is combined with a standard horn antenna to form an antenna. The other is a 3dB coupler plus Ortho-mode Transducers (OMT), with a standard horn antenna to form the antenna. Precision machining strictly guarantees the mouth size and opening angle of these horn antennas. These horn antennas are very suitable for antenna far-field testing, RF radiation testing and some other applications. It can be customized according to the needs of users.

For Example

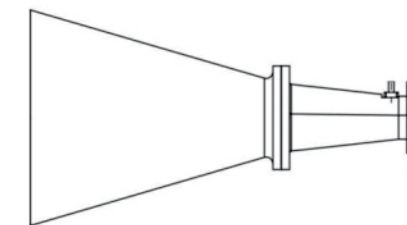

Volt Standing Wave Ratio

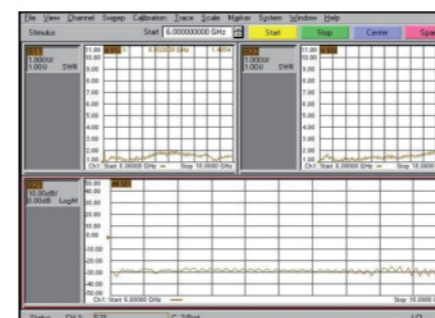

Gain

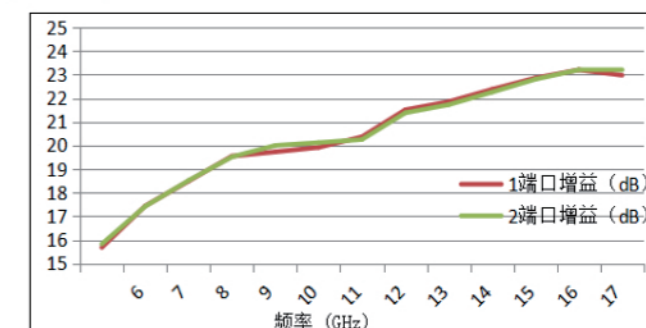

Model	Frequency (GHz)	Polarization	Gain (dBi)	VSWR	Interface	Dimension			Datash eet
						L	W	H	
RM-DCPHA82124-15	8.2-12.4	Dual Circular Pol.	15	≤2	SMA-K	/	/	/	Detail
RM-DCPHA1114-15	11-14	Dual Circular Pol.	15	≤2	SMA-K	/	/	/	Detail
RM-DCPHA238312-15	23.8-31.2	Dual Circular Pol.	15	≤2	2.92mm-K	/	/	/	Detail
RM-DCPHA105145-20	10.5-14.5	Dual Circular	20	1.5	2.92mm-K	115	109	210	Detail

8 Corrugated Horn Antenna

1. The radiation pattern is symmetric (axisymmetric).
2. Low sidelobe, can reach -25dB typical value in the whole waveguide frequency range, and can reach -40dB typical value in narrow band. Low cross polarization, low return loss.
3. Linear, dual linear, circular polarized square or waveguide output can be customized.
4. Different installation methods can be selected, the corresponding waveguide coaxial conversion can be selected.

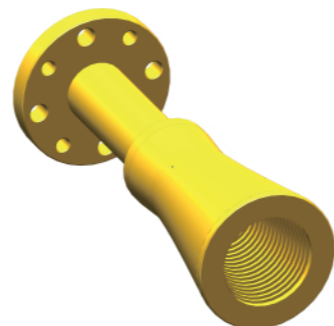

Model	Frequency (GHz)	Polarization	Waveguide	Gain(dBi)	VSWR	Interface
RM-CHA90-10	8.2-12.4	Linear	WR90	10	1.5	FBP100
RM-CHA90-10		Linear		10	1.5	SF/NF
RM-CHA90-15		Linear		15	1.5	FBP100
RM-CHA90-15		Linear		15	1.5	SF/NF
RM-CHA90-20		Linear		20	1.5	FBP100
RM-CHA90-20		Linear		20	1.5	SF/NF
RM-CHA75-10	10.0-15.0	Linear	WR75	10	1.5	FBP120
RM-CHA75-10		Linear		10	1.5	SF/NF
RM-CHA75-15		Linear		15	1.5	FBP120
RM-CHA75-15		Linear		15	1.5	SF/NF
RM-CHA75-20		Linear		20	1.5	FBP120
RM-CHA75-20		Linear		20	1.5	SF/NF
RM-CHA62-10	12.4-18.0	Linear	WR62	10	1.5	FBP140
RM-CHA62-10		Linear		10	1.5	SF/NF
RM-CHA62-15		Linear		15	1.5	FBP140
RM-CHA62-15		Linear		15	1.5	SF/NF
RM-CHA62-20		Linear		20	1.5	FBP140
RM-CHA62-20		Linear		20	1.5	SF/NF
RM-CHA51-10	15.0-22.0	Linear	WR51	10	1.5	FBP180
RM-CHA51-10		Linear		10	1.5	SF
RM-CHA51-15		Linear		15	1.5	FBP180
RM-CHA51-15		Linear		15	1.5	SF
RM-CHA51-20		Linear		20	1.5	FBP180
RM-CHA51-20		Linear		20	1.5	SF
RM-CHA42-10	18.0-26.5	Linear	WR42	10	1.5	FBP220
RM-CHA42-10		Linear		10	1.5	SF/KF/3.5F
RM-CHA42-15		Linear		15	1.5	FBP220
RM-CHA42-15		Linear		15	1.5	SF/KF/3.5F
RM-CHA42-20		Linear		20	1.5	FBP220
RM-CHA42-20		Linear		20	1.5	SF/KF/3.5F

RM-CHA34-10	22.0-33.0	Linear	WR34	10	1.5	FBP260	
RM-CHA34-10		Linear		10	1.5	KF	
RM-CHA34-15		Linear		15	1.5	FBP260	
RM-CHA34-15		Linear		15	1.5	KF	
RM-CHA34-20		Linear		20	1.5	FBP260	
RM-CHA34-20		Linear		20	1.5	KF	
RM-CHA28-10	26.5--40.0	Linear	WR28	10	1.5	FBP320	
RM-CHA28-10		Linear		10	1.5	KF/2.4F	
RM-CHA28-15		Linear		15	1.5	FBP320	
RM-CHA28-15		Linear		15	1.5	KF/2.4F	
RM-CHA28-20		Linear		20	1.5	FBP320	
RM-CHA28-20		Linear		20	1.5	KF/2.4F	
RM-CHA28-15	23.5-43.5	Dual Linear	WR28	15	1.5	FBP320	
RM-CHA28-15	23.5-40.0	Dual Linear		15	1.5	KF	
RM-CHA28-15	23.5-43.5	Dual Linear		15	1.5	2.4F	
RM-CHA28-20	23.5-43.5	Dual Linear		20	1.5	FBP320	
RM-CHA28-20	23.5-40.0	Dual Linear		20	1.5	KF	
RM-CHA28-20	23.5-43.5	Dual Linear		20	1.5	2.4F	
RM-CHA28-20	24.5-50.0	Dual Linear		20	1.5	FBP320	
RM-CHA28-20	24.5-50.0	Dual Linear		20	1.5	2.4F	
RM-CHA22-10	33.0-50.0	Linear		WR22	10	1.5	FUGP400
RM-CHA22-10		Linear			10	1.5	2.4F
RM-CHA22-15		Linear	15		1.5	FUGP400	
RM-CHA22-15		Linear	15		1.5	2.4F	
RM-CHA22-20		Linear	20		1.5	FUGP400	
RM-CHA22-20		Linear	20		1.5	2.4F	
RM-CHA19-10	40.0-60.0	Linear	WR19	10	1.5	FUGP500	
RM-CHA19-10		Linear		10	1.5	1.85F	
RM-CHA19-15		Linear		15	1.5	FUGP500	
RM-CHA19-15		Linear		15	1.5	1.85F	
RM-CHA19-20		Linear		20	1.5	FUGP500	
RM-CHA19-20		Linear		20	1.5	1.85F	
RM-CHA15-10	50.0-75.0	Linear	WR15	10	1.5	FUGP620	
RM-CHA15-10		Linear		10	1.5	1.85F	
RM-CHA15-15		Linear		15	1.5	FUGP620	
RM-CHA15-15		Linear		15	1.5	1.85F	
RM-CHA15-20		Linear		20	1.5	FUGP620	
RM-CHA15-20		Linear		20	1.5	1.85F	
RM-CHA12-10	60.0-90.0	Linear	WR12	10	1.5	FUGP740	
RM-CHA12-15		Linear		15	1.5	FUGP740	
RM-CHA12-20		Linear		20	1.5	FUGP740	
RM-CHA10-10	75.0-110.0	Linear	WR10	10	1.5	FUGP900	
RM-CHA10-15		Linear		15	1.5	FUGP900	
RM-CHA10-20		Linear		20	1.5	FUGP900	

9 Planar Antenna

Antennas system composed of many identical single antennas (such as symmetrical antennas) arranged in a certain order is also called an antenna array. The independent units that make up the antenna array are called array elements or antenna elements. If the array elements are arranged in a straight line or on a plane, it is called a linear array or a planar array.

For Example

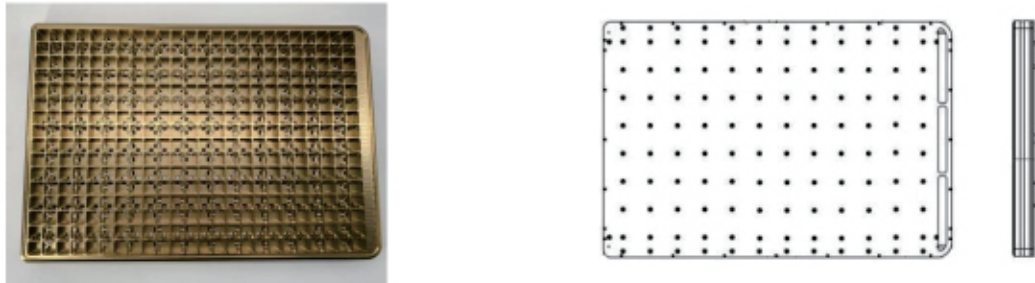

Gain

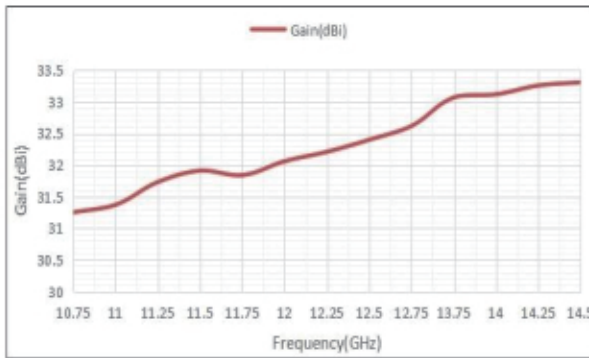

Patterns

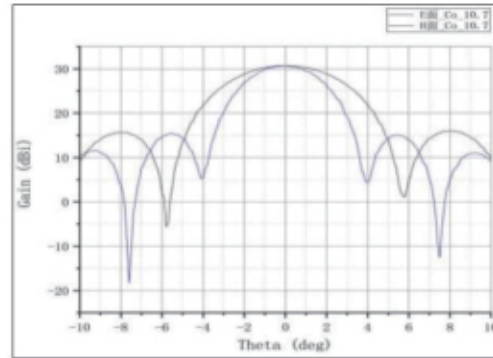

Model	Frequency (GHz)	Gain(dBi)	Interface	Dimension(mm)			Material	Datasheet
				W	H	L		
RM-PA1075145-32	10.75-14.5	32Typ.	WR75/WR62	460	304	32.2	Al	Detail
RM-PA10145-30	10-14.5	30Typ.	WR75	288	223	46.5	Al	Detail
RM-SWA910-22	9-10	22 Typ.	SAM-K	260	89	20	Al	Detail

10 Planar Spiral Antenna

Planar Spiral Antennas are antennas with a helical shape. Each consists of a metal helix with good electrical conductivity, usually fed by a coaxial line, the core wire of the coaxial line is connected to one end of the helix, The outer conductor of the coaxial line is connected to the grounded metal mesh (or plate). The radiation direction of the helical antenna is related to the circumference of the helix when the circumference of the helix is much smaller than one wavelength, The direction of the strongest radiation is perpendicular to the helical axis, when the circumference of the helix is on the order of one wavelength and the strongest radiation appears in the direction of the helical axis.

For Example



Volt Standing Wave Ratio

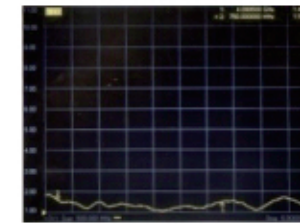

Gain

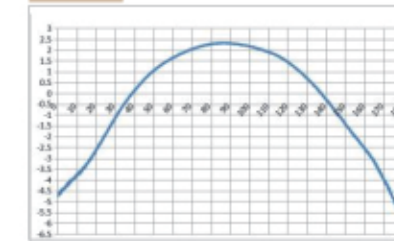

Model	Frequency (GHz)	Polarization	Gain (dBi)	VSWR	Connector	Dimension			Datasheet
						L	W	H	
RM-PSA0756-3	0.75-6	LHCP	3	2.0:1	SMA-50K	194	194	77.5	Detail
RM-PSA218-3	2-18	Linear	3	2.0:1	SMA-50K	86	86	83	Detail
RM-PSA052--6L	0.5-2	LHCP	-6	1.5:1	SMA-50K	/	/	/	Detail
RM-PSA052-06R		RHCP				/	/	/	Detail
RM-PSA084-0L	0.8-4	LHCP	0	1.5:1	SMA-50K	/	/	/	Detail
RM-PSA084-0R		RHCP				/	/	/	Detail
RM-PSA086-0L	0.8-8	LHCP	0	1.5:1	SMA-50K	/	/	/	Detail
RM-PSA086-0R		RHCP				/	/	/	Detail
RM-PSA18-2L	1-8	LHCP	2	1.5:1	SMA-50K	/	/	/	Detail
RM-PSA18-2R		RHCP				/	/	/	Detail
RM-PSA118-4L	1-18	LHCP	4	2.0:1	SMA-50K	/	/	/	Detail
RM-PSA118-4R		RHCP				/	/	/	Detail
RM-PSA218-0L	2-18	LHCP	2	2.0:1	SMA-50K	/	/	/	Detail
RM-PSA218-0R		RHCP				/	/	/	Detail

RM-PSA48-2L	4-8	LHCP	2	1.5:1	SMA-50K	/	/	/	Detail
RM-PSA48-2R		RHCP				/	/	/	Detail
RM-PSA418-3L	4-18	LHCP	3	2.0:1	SMA-50K	/	/	/	Detail
RM-PSA418-3R		RHCP				/	/	/	Detail
RM-PSA618-0L	6-18	LHCP	0	2.0:1	SMA-50K	/	/	/	Detail
RM-PSA618-0R		RHCP				/	/	/	Detail
RM-PSA818-0L	8-18	LHCP	0	2.0:1	SMA-50K	/	/	/	Detail
RM-PSA818-0R		RHCP				/	/	/	Detail
RM-PSA18265-0L	18-26.5	LHCP	0	1.5:1	2.92mm-50K	/	/	/	Detail
RM-PSA18265-0R		RHCP				/	/	/	Detail
RM-PSA1840-2L	18-40	LHCP	2	2.0:1	2.92mm-50K	/	/	/	Detail
RM-PSA1840-2R		RHCP				/	/	/	Detail

11 Log Spiral Antenna

Circular polarization enables the logarithmic helical antenna to quickly discover electromagnetic frequency radiation sources;

1. Wide bandwidth.
2. Up to ten octaves.
3. The outer helix can dissipate heat better.

For Example

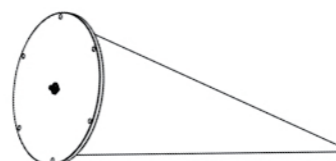

Voltage Standing Wave Ratio

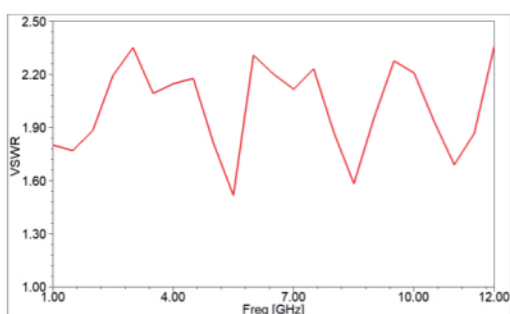

Gain

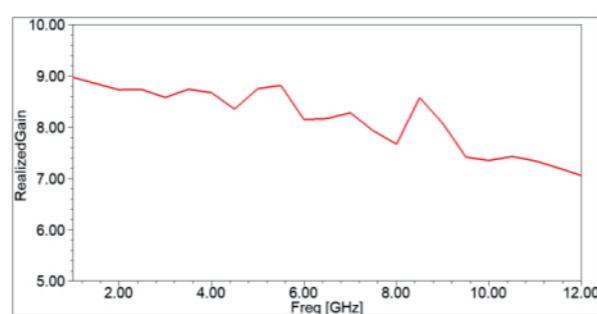

Model	Frequency (GHz)	Polarization	Gain (dBi)	VSWR	Connector	Dimension			Data sheet
						L	W	H	
RM-LSA021--4	0.2-1.0	RHCP/LHCP	-9~5	3.0	N-50K	/	/	/	Detail
RM-LSA110-3	1.0-10.0	RHCP/LHCP	1-5	3.0	N-50K	/	/	/	Detail
RM-LSA112-3R	1-12	RHCP	3	2.0:1	N-50K	167	167	237	Detail

12 Log Periodic Antenna

The electrical characteristics of the log-periodic antenna, such as impedance, pattern, gain, and standing wave ratio, change periodically with the logarithm of the frequency, and remain basically unchanged in a wide frequency band. The antenna series can cover 100:1 ultra-wideband bandwidth. The gain can reach as high as 9dB. The hybrid design scheme is adopted at extremely low frequencies, so that the size of the antenna has a high integration with respect to the wavelength. The log-periodic antenna is a light-weight, medium-gain log-periodic dipole antenna that is designed for transmitting and receiving signals in a wide frequency range, and all adopt linear polarization, which is easy to adjust the polarization on any plane.



Voltage Standing Wave Ratio

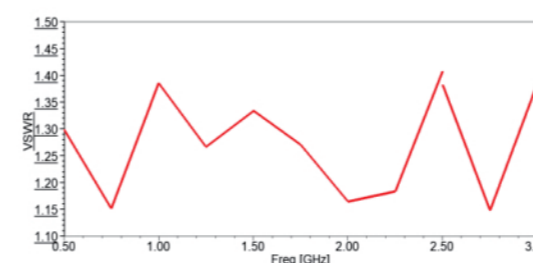

Gain

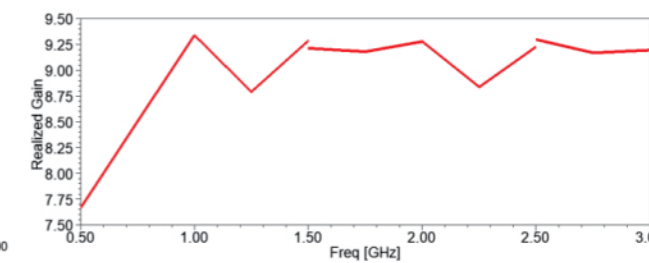

Model	Frequency (GHz)	Polarization	Gain (dBi)	Connector	Dimension(mm)			Material	Data sheet
					W	H	L		
RM-LPA202000	30-3000	Linear	6-8	N-K	1330	654	460	Al	Detail
RM-LPA2503000	250-3000	Linear	8 Typ.	N-K	840	25	2040	Al	Detail
RM-LPA2504000	250-4000	Linear	8 Typ.	N-K	729	344	775	Al	Detail
RM-LPA3002000	300-2000	Linear	8 Typ.	N-K	840	25	2040	Al	Detail
RM-LPA4002000	400-2000	Linear	8 Typ.	N-K	459	19.4	833	Al	Detail
RM-LPA4003000	400-3000	Linear	8 Typ.	N-K	459	19.4	833	Al	Detail
RM-LPA5002000	500-2000	Linear	8 Typ.	N-K	459	19.4	833	Al	Detail
RM-LPA5003000	500-3000	Linear	8 Typ.	N-K	459	19.4	833	Al	Detail
RM-LPA5004000	500-4000	Linear	8 Typ.	N-K	459	19.4	833	Al	Detail
RM-LP5006000	500-6000	Linear	8 Typ.	N-K	398	25	1030	Al	Detail
RM-LPA5008000	500-8000	Linear	8 Typ.	N-K	364	172	390	Al	Detail
RM-LPA10006000	1000-6000	Linear	8 Typ.	N-K	430	172	381	Al	Detail

13 Microstrip Array Antenna

The microstrip array antennas are on a thin dielectric substrate, one side is attached with a thin metal layer as a ground plane, and the other side is made of a metal patch of a certain shape by photolithography and etching.

An antenna formed by feeding a patch with a microstrip line or a coaxial probe.

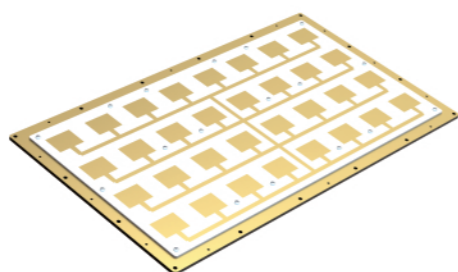

Volt Standing Wave Ratio

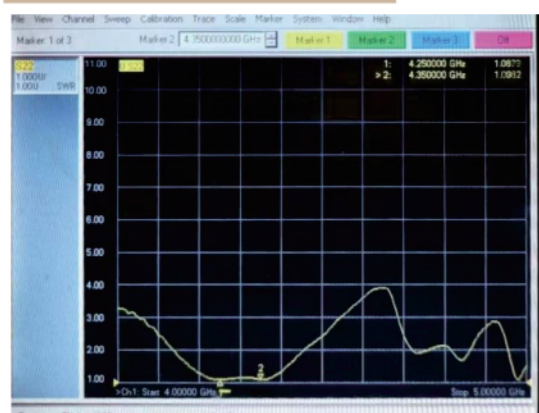

Patterns

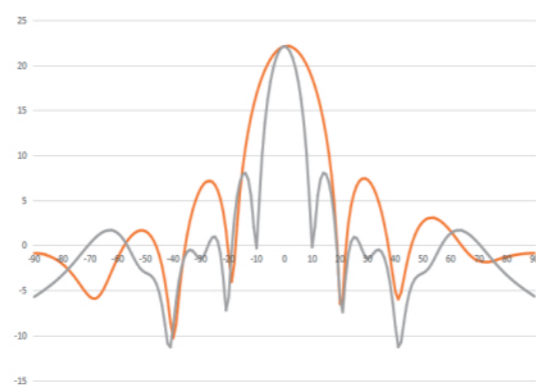

Model	Frequency (GHz)	Gain (dBi)	VSWR	Connector	Impedance(Ω)	Datasheet
RM-MAA041-15	0.4-1	15	2:1	N	50	Detail
RM-MAA12-15	1-2	15	2:1	N	50	Detail
RM-MAA2224-15	2.2-2.4	15	2:1	SMA	50	Detail
RM-MAA24-15	2-4	15	2:1	N/SMA	50	Detail
RM-MAA48-15	4-8	15	2:1	SMA	50	Detail
RM-MAA425535-20	4.25-4.35	20	2:1	N-K	50	Detail
RM-MAA7479-15	7.4-7.9	15	2:1	SMA	50	Detail
RM-MAA81251-15	8-12.5	15	2:1	SMA	50	Detail
RM-MAA935985-15	9.35-9.85	15	2:1	SMA	50	Detail
RM-MAA945975-15	9.45-9.75	15	2:1	N/SMA	50	Detail
RM-MAA95105-15	9.5-10.5	15	2:1	N/SMA	50	Detail
RM-MAA125181-15	12.5-18	15	2:1	SMA	50	Detail
RM-MAA164516951-15	16.45-16.95	15	2:1	SMA	50	Detail
RM-MAA24255-15	24-25.5	15	2.5:1	SMA-50K	50	Detail

14 Triangular Reflector

RF Miso triangular reflectors are used for accurate simulation of radar targets and radar system calibration. The standard side length range of TCR is 18-1016 mm, the material is aluminum, and the surface has a golden chemical film (color conductive oxidation). The TCR has threaded mounting holes for easy mounting on a tripod for quick system setup. We can customize sizes and specifications as required.

Features: side length 18mm-1016mm

High directivity and gain, low cost, easy installation, customizable

For Example

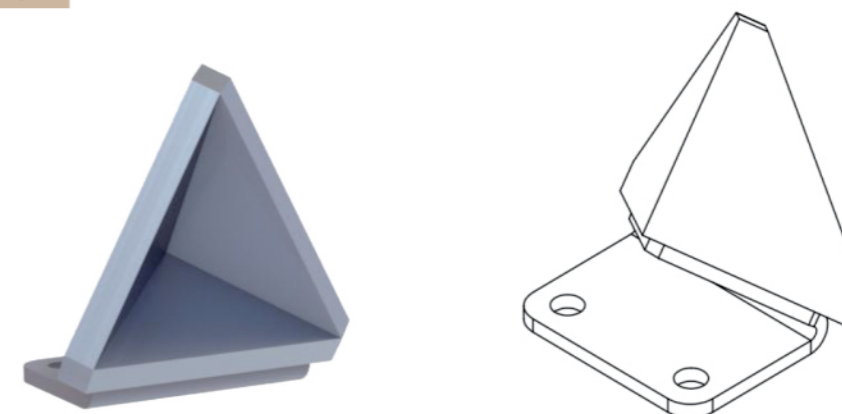

Model	Edge Length(mm)	Weight	Datasheet
RM-TCR18	18	0.00249	Detail
RM-TCR35.6	35.6	0.011	Detail
RM-TCR45.7	45.7	0.015	Detail
RM-TCR50	50	0.018	Detail
RM-TCR61	61	0.028	Detail
RM-TCR81.3	81.3	0.056	Detail
RM-TCR109.2	109.2	0.099	Detail
RM-TCR152.4	152.4	0.221	Detail
RM-TCR203.2	203.2	0.479	Detail
RM-TCR215.9	215.9	0.605	Detail
RM-TCR226.1	226.1	0.721	Detail
RM-TCR254	254	0.783	Detail
RM-TCR330	330	1.681	Detail
RM-TCR342.9	342.9	1.952	Detail
RM-TCR406.4	406.4	2.505	Detail
RM-TCR609.6	609.6	7.048	Detail
RM-TCR762	762	10.033	Detail
RM-TCR1016	1016	23.913	Detail

15 Waveguide Probe

RF Miso's waveguide probe antennas are often used to measure the gain of other antennas by comparing the signal levels of the probe antenna and the antenna under test, providing a solution for the test and calibration of the approach antenna. The probe antenna of RF MISO is mainly a standard waveguide input, the gain range is 22GHz-110GHz, the polarization method is linear polarization, the material is brass, and the surface is gold-plated. We can provide customers with absorbing materials that match the probe.



Frequency: 22-170GHz

VSWR: ≤1.5

Gain: 8dBi

Interface: Waveguide

Patterns

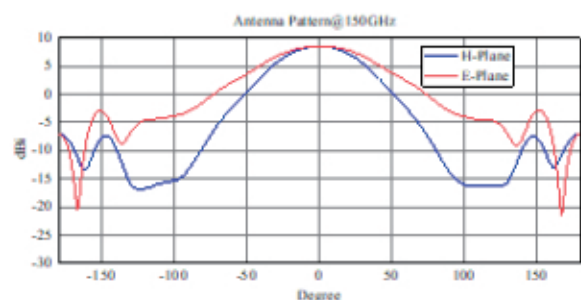

Gain

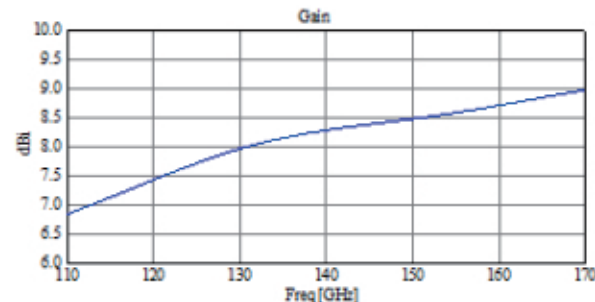

Model	Frequency (GHz)	Polarization	Gain (dBi)	Connector	Dimension(mm)			Material	Datasheet
					W	H	L		
RM-WPA6-8	110-170	Linear	8	WR6	19.1	19.1	25.4	Brass	Detail
RM-WPA8-8	90-140	Linear	8	WR8	19.1	19.1	25.4	Brass	Detail
RM-WPA10-8	75-110	Linear	8	WR10	19.1	19.1	25.4	Brass	Detail
RM-WPA12-8	60-90	Linear	8	WR12	19.1	19.1	30.5	Brass	Detail
RM-WPA15-8	50-70	Linear	8	WR15	19.1	19.1	38.1	Brass	Detail
RM-WPA19-8	40-60	Linear	8	WR19	28.6	28.6	50.8	Brass	Detail
RM-WPA22-8	33-50	Linear	8	WR22	28.6	28.6	50.8	Brass	Detail
RM-WPA28-8	26.5-40	Linear	8	WR28	19.1	19.1	71.1	Brass	Detail
RM-WPA34-8	22-33	Linear	8	WR30	22.2	22.2	86.4	Brass	Detail

16 Right Angle Waveguide to Coaxial Adapter

Right Angle Waveguide to Coaxial Adapters are converter product that transmits microwaves in waveguides to coaxial lines in radar and communication trunk lines.

Waveguide types include standard types such as rectangle, flat rectangle, medium flat rectangle, circle, single ridge and double ridge, and connector types include N, TNC, SMA, 2.92mm (K), 2.4mm, etc.

Performance characteristics: low standing wave, low loss, high power, covering the working bandwidth of the waveguide main mode, the structure size and electrical performance can be customized according to user needs.

For Example

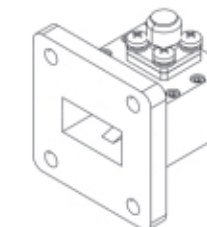

Volt Standing Wave Ratio

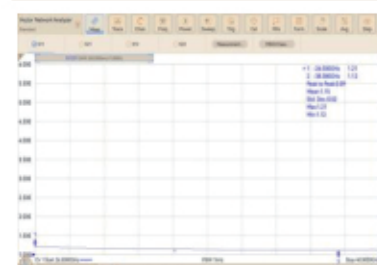

Insertion loss

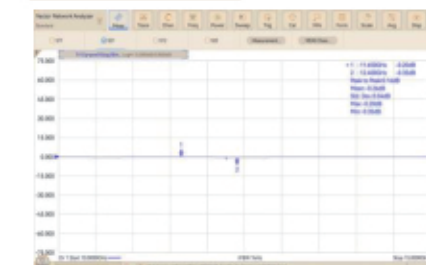

Model	Frequency	VSWR	Insertion Loss	Connector	Waveguide	Flange	Datasheet
RM-WCA10	75-110	≤1.6	≤1.2	1.0mm-50k	WR10	FUGP900	Detail
RM-WCA12	60-90	≤1.6	≤1.2	1.0mm-50k	WR12	FUGP740	Detail
RM-WCA15-1.85	50-65	≤1.5	≤1.2	1.85mm-50k	WR15	FUGP620	Detail
RM-WCA15-1.0	50-75	≤1.5	≤1.0	1.0mm-50k	WR15	FUGP620	Detail
RM-WCA19-2.4	40-50	≤1.5	≤0.8	2.4mm-50k	WR19	FUGP500	Detail
RM-WCA19-1.85	40-60	≤1.5	≤0.8	1.85mm-50k	WR19	FUGP500	Detail
RM-WCA28	26.5-40	≤1.3	≤0.45	2.92-K/2.4mm(K)	WR28	FBP320	Detail
RM-WCA34	22-33	≤1.3	≤0.45	2.92-K	WR34	FBP260	Detail
RM-WCA42	18-26.5	≤1.3	≤0.4	SMA-K	WR42	FBP220	Detail
RM-WCA51	15-22	≤1.3	≤0.4	SMA-K	WR51	FBP180	Detail
RM-WCA62	12.4-18	≤1.3	≤0.4	SMA-K/3.5mm-K	WR62	FBP140	Detail
RM-WCA75	10-15	≤1.3	≤0.35	SMA-K	WR75	FBP120	Detail
RM-WCA90	8.2-12.4	≤1.3	≤0.35	SMA-K/3.5mm-K	WR90	FBP100	Detail
RM-WCA112	7.05-10	≤1.3	≤0.35	SMA-K/N-K	WR112	FBP84	Detail
RM-WCA137	5.85-8.2	≤1.3	≤0.3	N-K	WR137	FDP70	Detail
RM-WCA159	4.9-7.05	≤1.3	≤0.3	N-K	WR159	FDP58	Detail
RM-WCA187	3.95-5.85	≤1.3	≤0.3	N-K	WR187	FDP48	Detail
RM-WCA229	3.3-4.9	≤1.3	≤0.2	N-K/7mm	WR229	FDP40	Detail
RM-WCA284	2.6-3.95	≤1.3	≤0.2	N-K	WR284	FDP32	Detail
RM-WCA340	2.2-3.3	≤1.3	≤0.2	N-K	WR340	FDP26	Detail
RM-WCA430	1.7-2.6	≤1.3	≤0.2	N-K	WR430	FDP22	Detail

17 Vacuum Welding Products

The vacuum brazing process has been widely used in metal products. Because of its several characteristics.

1. Brazed parts will not be oxidized, such as aerospace, precision parts.
2. Brazed parts have high strength. Such as waveguide products, aviation parts.
3. Brazed parts have good airtightness, such as water-cooled plates, water-cooled chassis, radiators, etc.

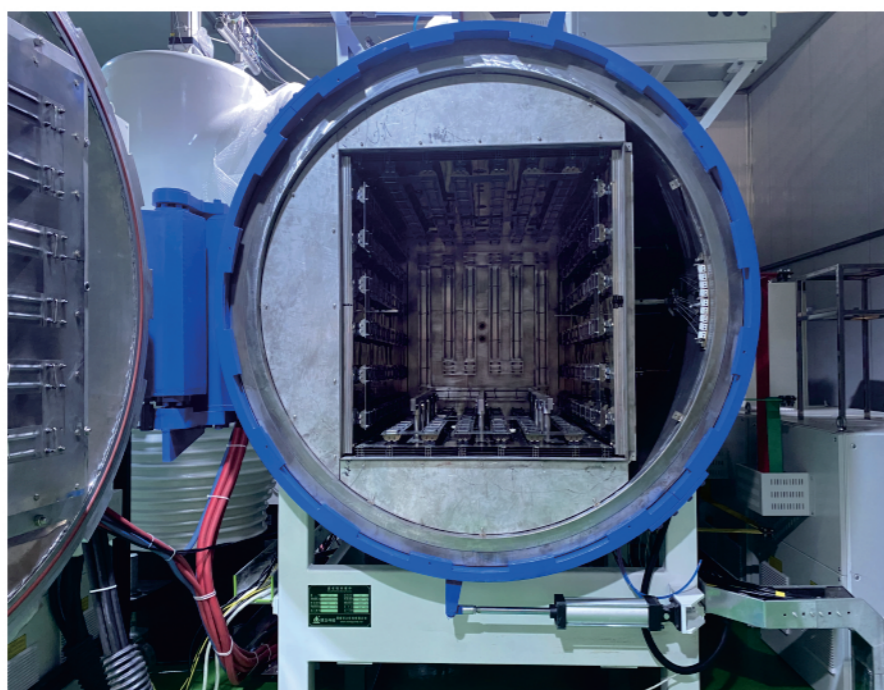

Vacuum Brazing Furnace

1 Slotted waveguied array antenna

Features

1. Up to 110GHz
2. Up to 20 layers can be soldered
3. Welded products have high strength

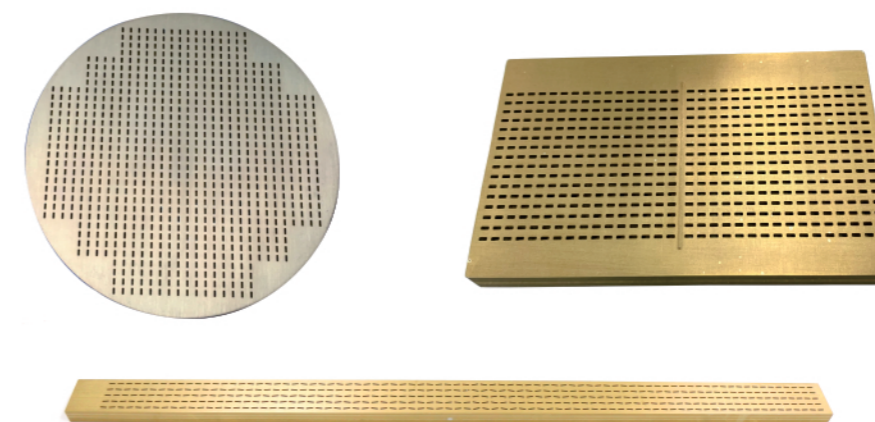

2 Water-cooled plate&water-cooled chassis

Features

Good air tightness, no water leakage

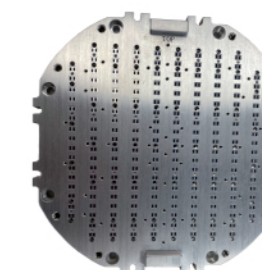

3 Waveguide products

